

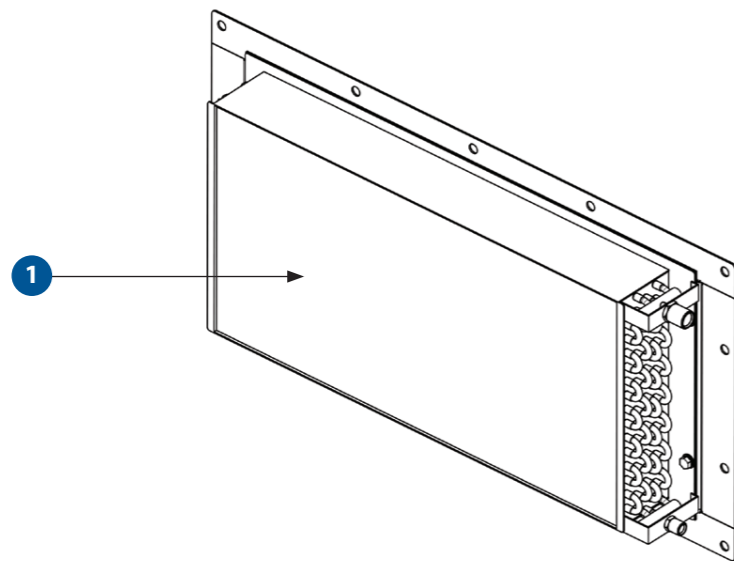

TCW5

WALL MOUNTED CONDENSER

TCW5BX1 | TCW5BX2

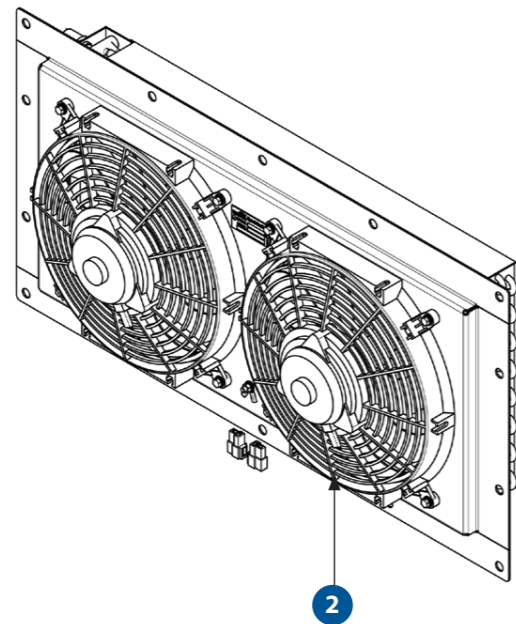

SPARE PARTS

PART NO.	DESCRIPTION	QTY
1 H0039196	CONDENSER COIL 600MM X 305MM X 66MM 4RW (TCW5BX1)	1
H0095147	CONDENSER COIL 600MM X 305MM X 66MM 4RW (TCW5B2)	1
2 H0051777	FAN AXIAL ASSEMBLY 280MM 24VDC	2

SPECIFICATIONS

	METRIC	IMPERIAL
Cooling Capacity	4 kW	13648 BTU
Fan Speeds	1	1
Air Flow	500 l/s	1059 CFM
Power Supply	24 VDC	24 VDC
Current Draw	8A	8A
Refrigerant	R134a	R134a
Maximum Ambient Temperature	54°C	129°F
Weight (nominal)	17.0 Kg	37.4 lbs

MAINTENANCE

ANNUAL / 4,800 HOURS

H0051777 FAN AXIAL ASSEMBLY 280MM 24VDC

Please contact SIGMA for more information including details on an overhaul scope and interval. Maintenance periods and scope are dependent on application and site conditions, and are to be used as a guide.

COMPANION ITEMS

PART NO.	DESCRIPTION
TFF5BX1	5kW Evaporator Floor Mounted 12V
TFF5BX2	5kW Evaporator Floor Mounted 24V
EB9P4X	Pressuriser
HDC150	Hydraulic Compressor
AU2961001	Electric Compressor
AU270312	Engine Driven Compressor
AU270311	Engine Driven Compressor
H0081855	Receiver Drier
AU531422	Receiver Drier
KNHV90043	Fitting Kit
KNHV90044	Installation Kits

DRAGLINE & SHOVEL

DRILL

EXCAVATOR

DOZER

TRUCK

WHEEL LOADER

CONSTRUCTION

UNDERGROUND EQUIPMENT

INDUSTRIAL

SMELTERS

RAIL SPECIAL VEHICLES