

TDR7

TRUCK ROOFTOP HVAC UNIT

TDR7BX1 | TDR7BX2

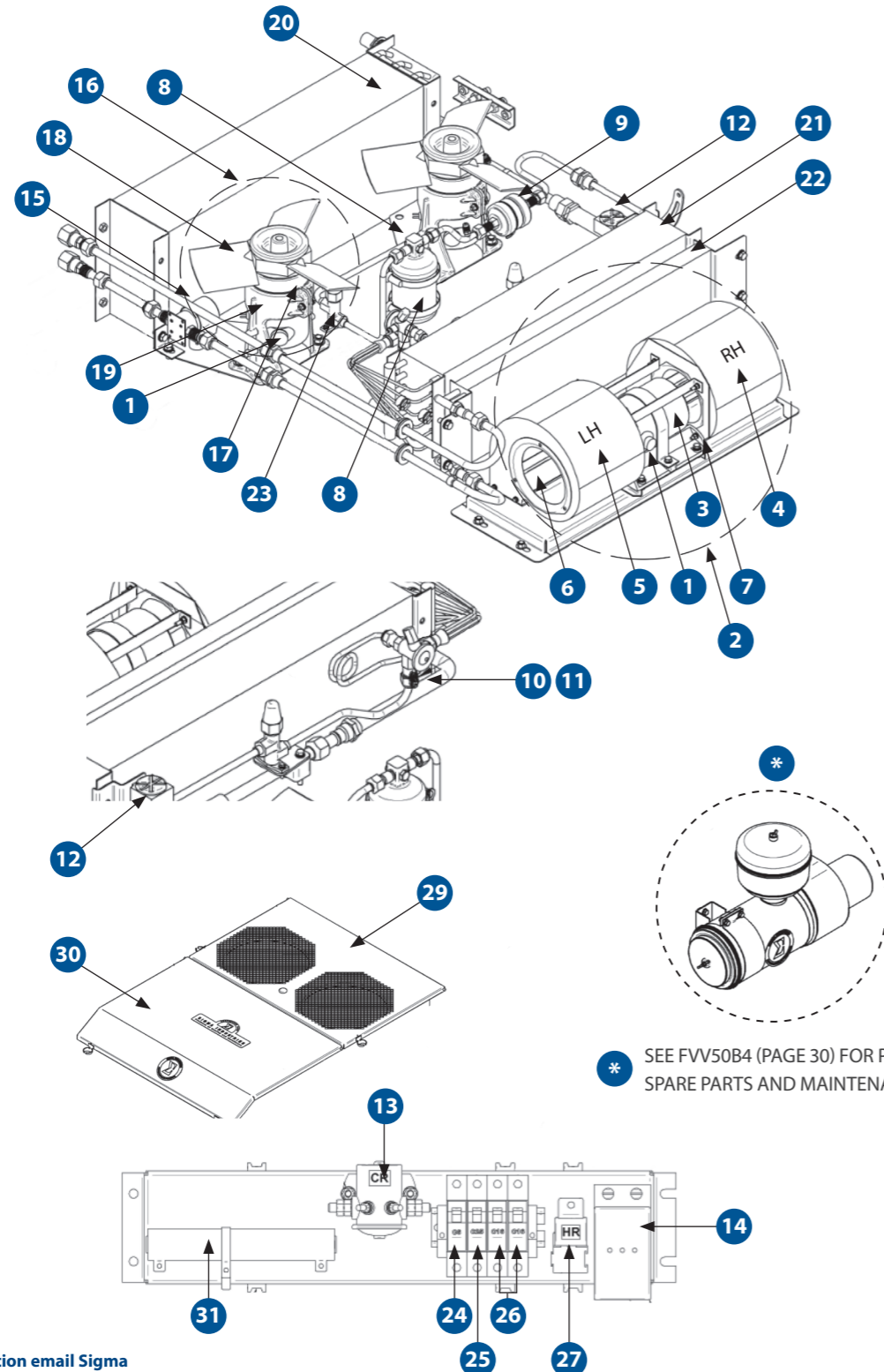

* SEE FVV50B4 (PAGE 30) FOR PRESSURISER SPARE PARTS AND MAINTENANCE

SPARE PARTS

PART NO.	DESCRIPTION	QTY
MC044S	RETURN AIR FILTER ASSEMBLY	1
1 AU320621	BRUSH MOTOR 24VDC EACH	6
2 AS5000224	EVAP FAN ASSEMBLY 24V	1
3 UE023	MOTOR 0.14W 24VDC D/S	1
4 AS5000222	BLOWER HOUSING W/ASSEMBLY RH	1
5 AS5000223	BLOWER HOUSING W/ASSEMBLY LH	1
6 UF171	BLOWER 121D X 127W X 3/8" DI	2
7 UC027	EVAPORATOR MOTOR MOUNT SUIT	1
8 AU531411	RECEIVER DRIER 3/8" 24UNF165MM HIGH	1
9 AU531357	DRIER 3/8" MF	1
10 AU521509	TX VALVE 2T 3/8" IN 1/2" OUT 1/4" EQ R134A	1
11 AU521508	TX ORIFICE 2T R22 #06	1
12 UE016	THERMOSTAT DEICE STUD	1
13 UE072	RELAY 24VDC 70A AUTOMOTIVE	1
14 AU681925	THERMOSTAT 12 - 24 VDC WITH SENSOR + POT	1
15 UE057	VALVE SOLENOID 1/4" BSP 24VDC WATER	1
16 AS5000170	CONDENSER FAN ASSEMBLY 24V	2
17 UE026	MOTOR 0.14W 24VDC S/S	2
18 AU420229	FAN AXIAL 300MM 3 BLADES LB	2
19 UC028	CONDENSER MOTOR MOUNT SUIT UE025/26	4
20 AU110631	CONDENSER COIL 600 X 229 X 132 6RW (TDR7BX1)	1
AU110029	CONDENSER COIL 600 X 229 X 123 6RW (TDR7BX2)	1
21 AU120954	EVAPORATOR COIL 570MM X 152MM X 95MM 6RW	1
22 AU130002	HEATER COIL 570 X 152 X 32 2RW	1
23 AU517254	PCAV 3/8" SOLDER	2
24 AU641091	CIRCUIT BREAKER 6A 1POLE	1
25 AU641092	CIRCUIT BREAKER 25A 1POLE	1
26 AU641119	CIRCUIT BREAKER 16A 1 POLE	2

* SEE FVV50B4 (PAGE 30) FOR PRESSURISER SPARE PARTS AND MAINTENANCE

SPARE PARTS LIST CONTINUED NEXT PAGE

127 For more information email Sigma mid.aus@sigma-hvac.com

SPECIFICATIONS

	METRIC	IMPERIAL
Cooling Capacity	7.0 kW	23884 BTU
Heating Capacity	6.0 kW	20472 BTU
Fan Speeds	3	3
Air Flow	250 l/s	530 CFM
Fresh Air	30 l/s	64 CFM
Power Supply	24V / 12V	24V / 12V
Current Draw	33.5 / 67A	33.5 / 67A
Refrigerant	R134a	R134a
Maximum Ambient Temperature	54°C	129°F
Weight (nominal)	110.0 Kg	242.0 lbs
Technical Manual Reference	SM395-5000	SM395-5000
Dimension (L X W X H)	1100mm X 800mm X 288mm	43.3in X 31.5in X 11.3in

MAINTENANCE

MONTHLY / 400 HOURS	
MC044S	RETURN AIR FILTER ASSEMBLY
6 MONTHS / 2,400 HOURS	
AU320621	BRUSH MOTOR 24VDC EACH
AU320028	MOTOR BRUSH KIT - ASSEMBLY + HOLDER
ANNUAL / 4,800 HOURS	
UE023	MOTOR 0.14W 24VDC D/S
AU531411	RECEIVER DRIER 3/8" 24UNF165MM HIGH
AU531357	DRIER 3/8" MF
UE026	MOTOR 0.14W 24VDC S/S
AU320C007	MOTOR 650 ESX 24VDC S/S
3 YEARS / 14,400 HOURS	
AU521509	TX VALVE 2T 3/8" IN 1/2" OUT 1/4" EQ R134a
AU521508	TX ORIFICE 2T R22 #06
UE016	THERMOSTAT DEICE STUD
UE072	RELAY 24VDC 70A AUTOMOTIVE
AU681925	THERMOSTAT 12-24VDC WITH SENSOR + POT
AU523655	HP SWITCH 1/4" FF 2415kPa
AU523365	LP SWITCH 1/4" FF 205kPa
AU862211	SEAL RUBBER

Please contact SIGMA for more information including details on an overhaul scope and interval. Maintenance periods and scope are dependent on application and site conditions, and are to be used as a guide.

COMPANION ITEMS

PART NO.	DESCRIPTION
H0017479	Hydraulic Compressor
H0017481	Hydraulic Compressor
AU270306	Engine Driven Compressor
AU270307	Engine Driven Compressor

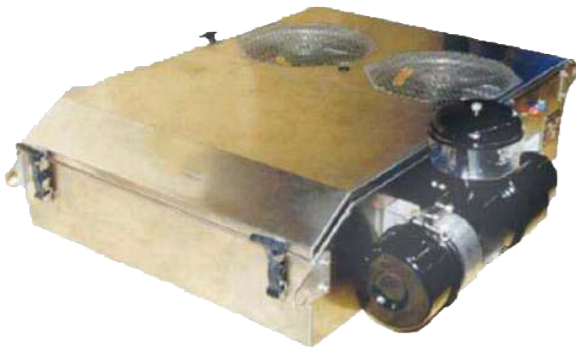

TDR7

TRUCK ROOFTOP HVAC UNIT

TDR7BX1 | TDR7BX2

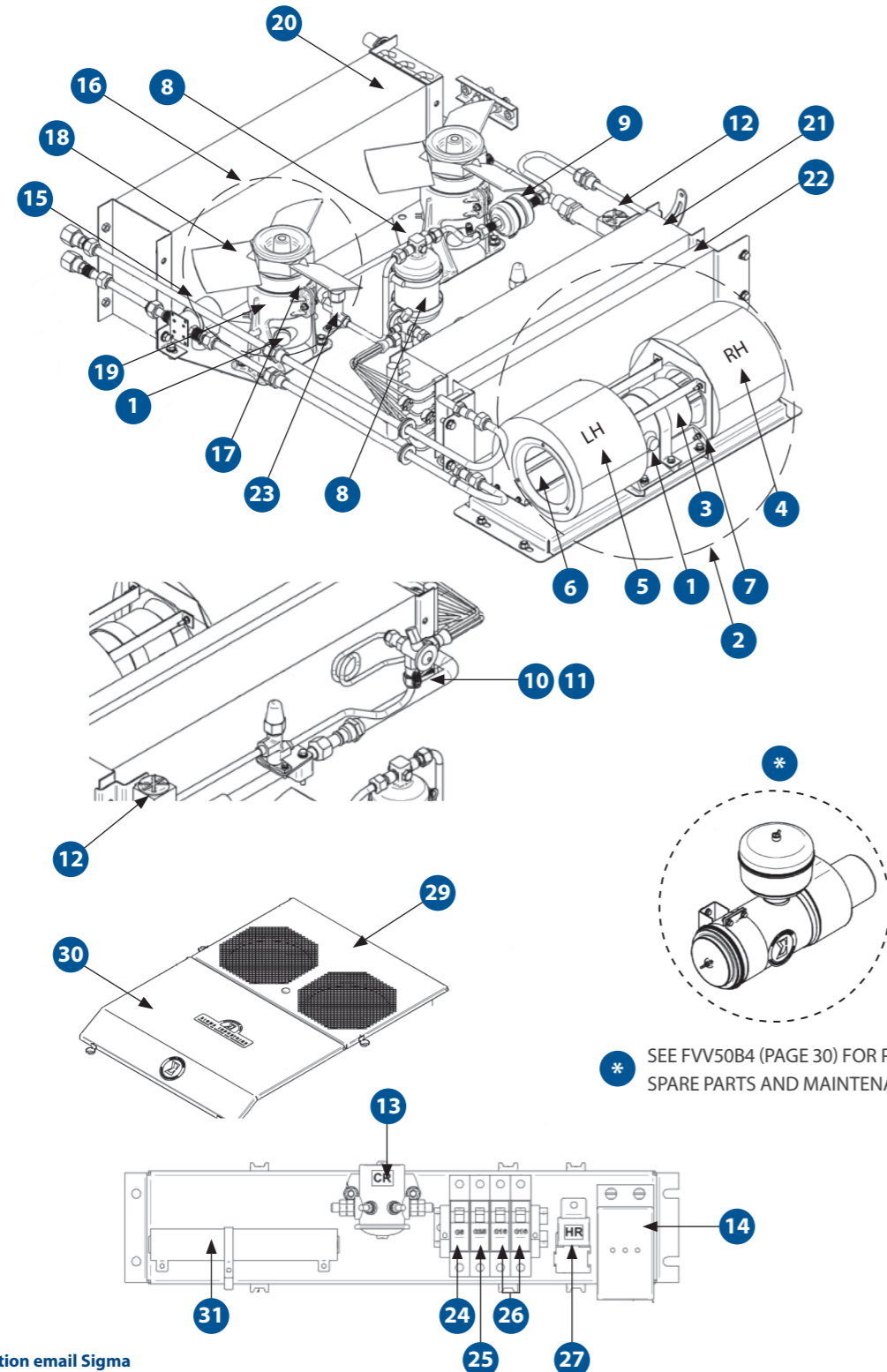

* SEE FVV50B4 (PAGE 30) FOR PRESSURISER SPARE PARTS AND MAINTENANCE

SPARE PARTS

PART NO.	DESCRIPTION	QTY
27	AU661483 RELAY 20A 24VDC 5 PIN	1
28	AU692105 RESISTOR 2 OHM 100W 1 CLIPS ADJUSTABLE	1
29	AS5000123 LID ASSEMBLY CONDENSER	1
30	AS5000124 LID ASSEMBLY EVAPORATOR	1
31	AU692105 RESISTOR 2 OHM	1
AU523655	HP SWITCH 1/4" FF 2415kPa	1
AU523365	LP SWITCH 1/4" FF 205kPa	1
AU82211	SEAL RUBBER	6.2
AU663562	ROTARY SWITCH A B C D MODE	1
AU663563	ROTARY SWITCH A B C D FAN	1
UC901	DIFFUSER 246MM X 104MM	2
UE700	CIRCUIT BEAKER 40A STUD TYP MANUAL	1
AU517502	VALVE ACCESS 1/4" 1/4" & 3/8" OD SOLDER	1
AU519074	ADAPTOR 134A 1/4" HIGH SIDE RED	1
AU519075	ADAPTOR 134A 1/4" LOW SIDE BLUE	1
AU635485	END BRACKET KLIPPON	2
AU851590	TOGGLE CLAMP RUBBER	4
AU853507	LEAF SPRING 105MM X 13MM	1
AU935432	FLAT NEOPRENE EXTRUSION	0.20
S5006029	MOTOR MOUNT CLAMP 97MM	1
UC020	HOSE CLEAR PVC 12 5MM ID	6
UC504	DRAIN NOZZLE 13MM	4
UF034	INLET RING 103.5MM	1
AU320028	MOTOR BRUSH KIT - ASSEMBLY + HOLDER	1

* SEE FVV50B4 (PAGE 30) FOR PRESSURISER SPARE PARTS AND MAINTENANCE

SPARE PARTS LIST CONTINUED ON PREVIOUS PAGE

129 For more information email Sigma mid.aus@sigma-hvac.com

SPECIFICATIONS

	METRIC	IMPERIAL
Cooling Capacity	7.0 kW	23884 BTU
Heating Capacity	6.0 kW	20472 BTU
Fan Speeds	3	3
Air Flow	250 l/s	530 CFM
Fresh Air	30 l/s	64 CFM
Power Supply	24V / 12V	24V / 12V
Current Draw	33.5 / 67A	33.5 / 67A
Refrigerant	R134a	R134a
Maximum Ambient Temperature	54°C	129°F
Weight (nominal)	110.0 Kg	242.0 lbs
Technical Manual Reference	SM395-5000	SM395-5000
Dimension (L X W X H)	1100mm X 800mm X 288mm	43.3in X 31.5in X 11.3in

MAINTENANCE

MONTHLY / 400 HOURS	
MC0445	RETURN AIR FILTER ASSEMBLY
6 MONTHS / 2,400 HOURS	
AU320621	BRUSH MOTOR 24VDC EACH
AU320028	MOTOR BRUSH KIT - ASSEMBLY + HOLDER
ANNUAL / 4,800 HOURS	
UE023	MOTOR 0.14W 24VDC D/S
AU531411	RECEIVER DRIER 3/8" 24UNF165MM HIGH
AU531357	DRIER 3/8" MF
UE026	MOTOR 0.14W 24VDC S/S
AU320C007	MOTOR 650 ESX 24VDC S/S
3 YEARS / 14,400 HOURS	
AU521509	TX VALVE 2T 3/8"IN 1/2"OUT 1/4"EQ R134a
AU521508	TX ORIFICE 2T R22 #06
UE016	THERMOSTAT DEICE STUD
UE072	RELAY 24VDC 70A AUTOMOTIVE
AU681925	THERMOSTAT 12-24VDC WITH SENSOR + POT
AU523655	HP SWITCH 1/4" FF 2415kPa
AU523365	LP SWITCH 1/4" FF 205kPa
AU862211	SEAL RUBBER

Please contact SIGMA for more information including details on an overhaul scope and interval. Maintenance periods and scope are dependent on application and site conditions, and are to be used as a guide.

COMPANION ITEMS

PART NO.	DESCRIPTION
H0017479	Hydraulic Compressor
H0017481	Hydraulic Compressor
AU270306	Engine Driven Compressor
AU270307	Engine Driven Compressor

128 For more information email Sigma mid.aus@sigma-hvac.com