

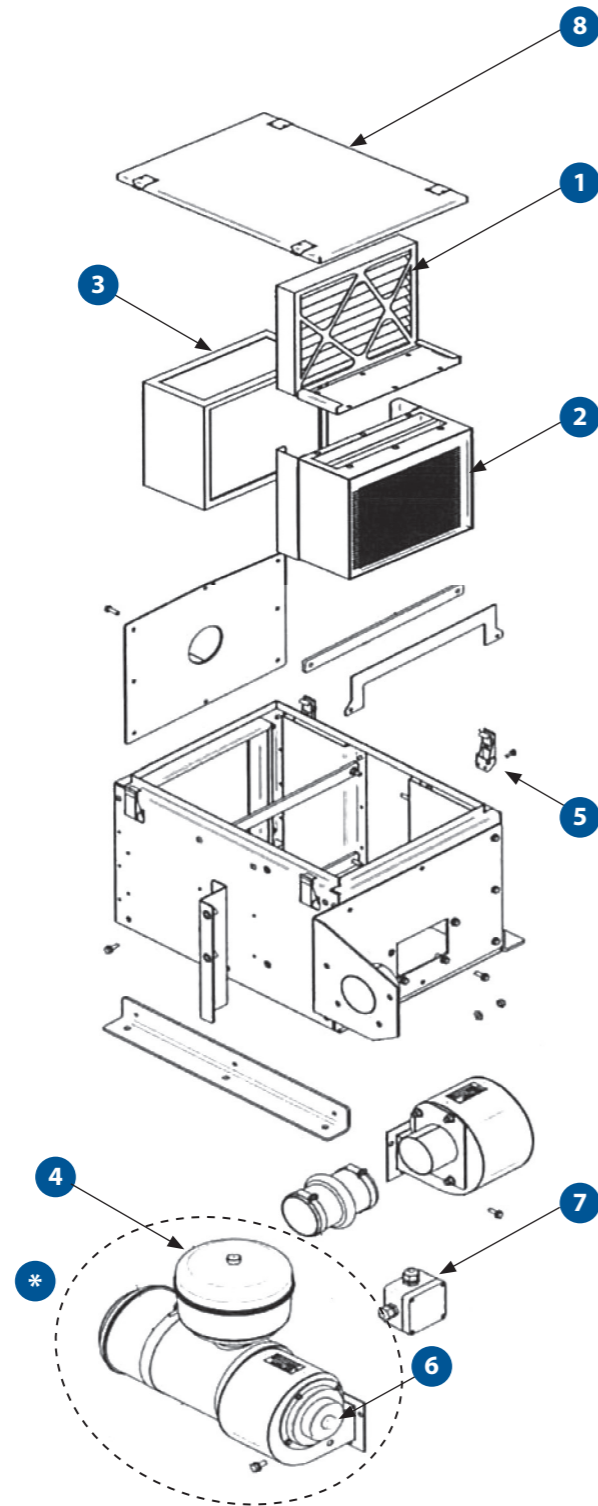

## PVV50B2 PRESSURISER



\* SEE EB9P4 (PAGE 26) AND EB9P4X (PAGE 28) FOR PRESSURISER SPARE PARTS AND MAINTENANCE

## SPARE PARTS

PART NO.	DESCRIPTION	QTY
1 AU460628	FILTER CARTRIDGE PLEAT 305MM X 305MM X 50MM	1
2 AS3505127 AU480004 AU480010 AU480011	FILTRATION MODULE ASSEMBLY MEDIA ACT ALUMINA MEDIA ACT CARBON MEDIA IMPREG CARBON	1 1 1 1
3 AU460863	FILTER 305MM X 305MM X 149MM METAL CASE	1
4 AU460963	PRE-CLEANER TS 3" INLET SMALL	1
5 UC310	CATCH TOGGLE OVERCENTRE SS	4
6 UE325	MOTOR 70W 24VDC PANCAKE	2
7 AU613047	TERMINAL BOX 80MM X 80MM	1
8 AS242124	LID ASSEMBLY	1
AU460706	FILTER ASSEMBLY ROUND 133 (STANDARD)	1
AU460080	FILTER CARTRIDGE ENDURANCE (UPGRADE)	1
AU410337	BLOWER 120D X 89W X 5/8 CCW SI	2
AU862211	SEAL RUBBER	2
S3750100	SEAL GASKET MOTOR	1
S3750101	SEAL GASKET CANISTER	1
UE369	CATCH STRIKER S/S	4
AU635405	TERMINAL BLOCK	1

\* SEE EB9P4 (PAGE 26) AND EB9P4X (PAGE 28) FOR PRESSURISER SPARE PARTS AND MAINTENANCE

## SPECIFICATIONS

	METRIC	IMPERIAL
<b>Fan Speeds</b>	1	1
<b>Fresh Air</b>	30 l/s	64 CFM
<b>Power Supply</b>	24V / 12V	24V / 12V
<b>Current Draw</b>	6 A / 12 A	6 A / 12 A
<b>Weight (nominal)</b>	60.0 Kg	132.0 lbs
<b>Dimension L X W X H</b>	695mm X 364mm X 520mm	27.4in X 14.3in X 20.5in

## MAINTENANCE

### 3 MONTHS / 900 HOURS

<b>AU460628</b>	FILTER CARTRIDGE PLEAT 305MM X 305MM X 50MM
<b>AU480004</b>	MEDIA ACT ALUMINA
<b>AU480010</b>	MEDIA ACT CARBON
<b>AU480011</b>	MEDIA IMPREG CARBON

### ANNUAL / 3,600 HOURS

<b>AU460863</b>	FILTER 305MM X 305MM X 149MM METAL CASE
<b>UE325</b>	MOTOR 70W 24VDC PANCAKE

### 3 YEARS / 10,800 HOURS

<b>AU460963</b>	PRE-CLEANER TS 3" INLET SMALL
<b>AU410337</b>	BLOWER 120D X 89W X 5/8 CCW SI

Please contact SIGMA for more information including details on an overhaul scope and interval. Maintenance periods and scope are dependent on application and site conditions, and are to be used as a guide.

## COMPANION ITEMS

PART NO.	DESCRIPTION
<b>KNHV90007</b>	Installation Kits

