

## PVV50M2 PRESSURISER

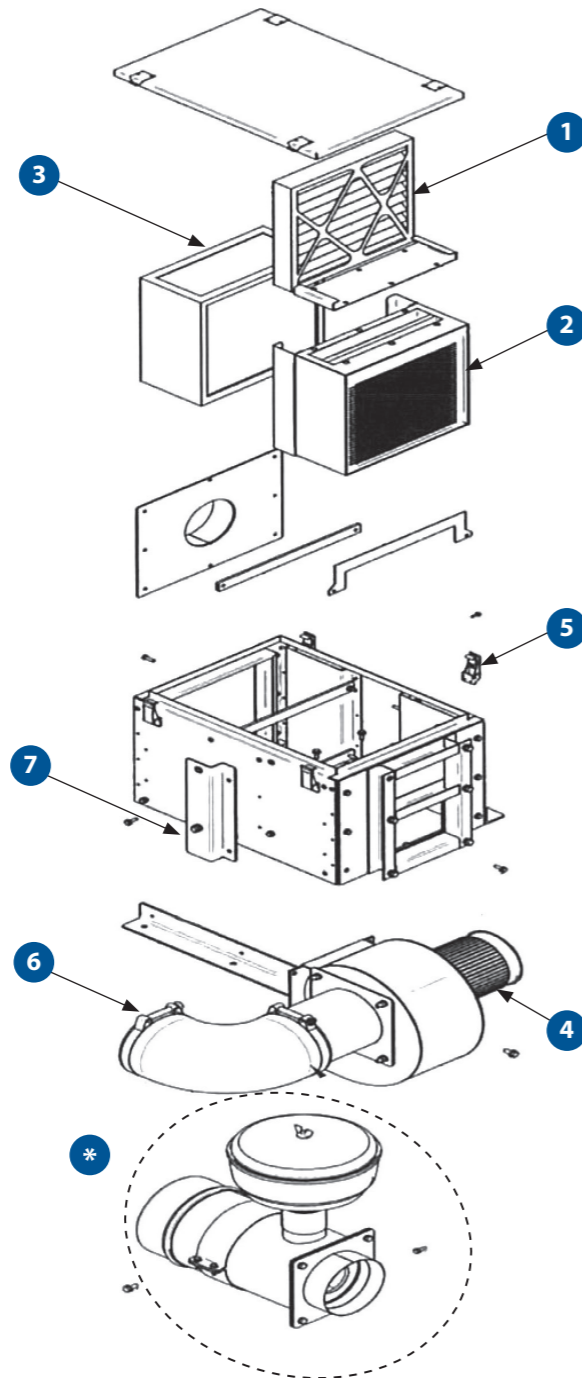

\* SEE FVV100 (PAGE 34) FOR PRESSURISER SPARE PARTS AND MAINTENANCE

## SPARE PARTS

PART NO.	DESCRIPTION	QTY
1 AU460628	FILTER CARTRIDGE PLEAT 305MM X 305MM X 50MM	1
2 AS3505127	FILTRATION MODULE ASSEMBLY	1
AU480004	MEDIA ACT ALUMINA	1
AU480010	MEDIA ACT CARBON	1
AU480011	MEDIA IMPREG CARBON	1
3 AU460863	FILTER 305MM X 305MM X 149MM METAL CASE	1
4 AU304150	MOTOR 0.55KW 415V 71 FL 2P	1
5 UC310	CATCH TOGGLE OVERCENTRE SS	4
6 UC265	ELBOW RUBBER 90DEG 6"	1
7 AS3505146	CANISTER MOUNTING BRACKET ASSEMBLY	1
AU460734	FILTER ELEMENT SUIT AU460727	1
AU460081	FILTER CARTRIDGE ENDURANCE FVV100	1
R1626027	GASKET OUTLET 206MM X 178MM	1
AU460727	FILTER CYCLONE 8" METAL	1
AU410520	BLOWER 178D X 102W X 19MM CCW SI	1
AS162609	FILTER CANNISTER ASSEMBLY	1
AS162611	FILTER SUPPORT CLAMP ASSEMBLY	1
AU872011	SHAFT EXTENSION 14MM F X 19MM	1
AU862211	SEAL RUBBER	2
UC266	CLAMP SUIT UC265	2
R1626026	GASKET INLET 200MM X 200MM X 140MM	1
AU460729	FILTER PRE-CLEANER 270MM	1

\* SEE FVV100 (PAGE 34) FOR PRESSURISER SPARE PARTS AND MAINTENANCE

## SPECIFICATIONS

	METRIC	IMPERIAL
<b>Fan Speeds</b>	1	1
<b>Fresh Air</b>	30 l/s	64 CFM
<b>Power Supply</b>	24V / 12V	24V / 12V
<b>Current Draw</b>	6 A / 12 A	6 A / 12 A
<b>Weight (nominal)</b>	60.0 Kg	132.0 lbs
<b>Dimension L X W X H</b>	695mm X 364mm X 520mm	27.4in X 14.3in X 20.5in

## MAINTENANCE

### 3 MONTHS / 900 HOURS

<b>AU460628</b>	FILTER CARTRIDGE PLEAT 305MM X 305MM X 50MM
<b>AU480004</b>	MEDIA ACT ALUMINA
<b>AU480010</b>	MEDIA ACT CARBON
<b>AU480011</b>	MEDIA IMPREG CARBON

### ANNUAL / 3,600 HOURS

<b>AU460863</b>	FILTER 305MM X 305X149MM METAL CASE
-----------------	-------------------------------------

### 3 YEARS / 10,800 HOURS

<b>AU460729</b>	FILTER PRE-CLEANER 270MM
<b>AU410520</b>	BLOWER 178D X 102W X 19MM CCW SI

Please contact SIGMA for more information including details on an overhaul scope and interval. Maintenance periods and scope are dependent on application and site conditions, and are to be used as a guide.

