

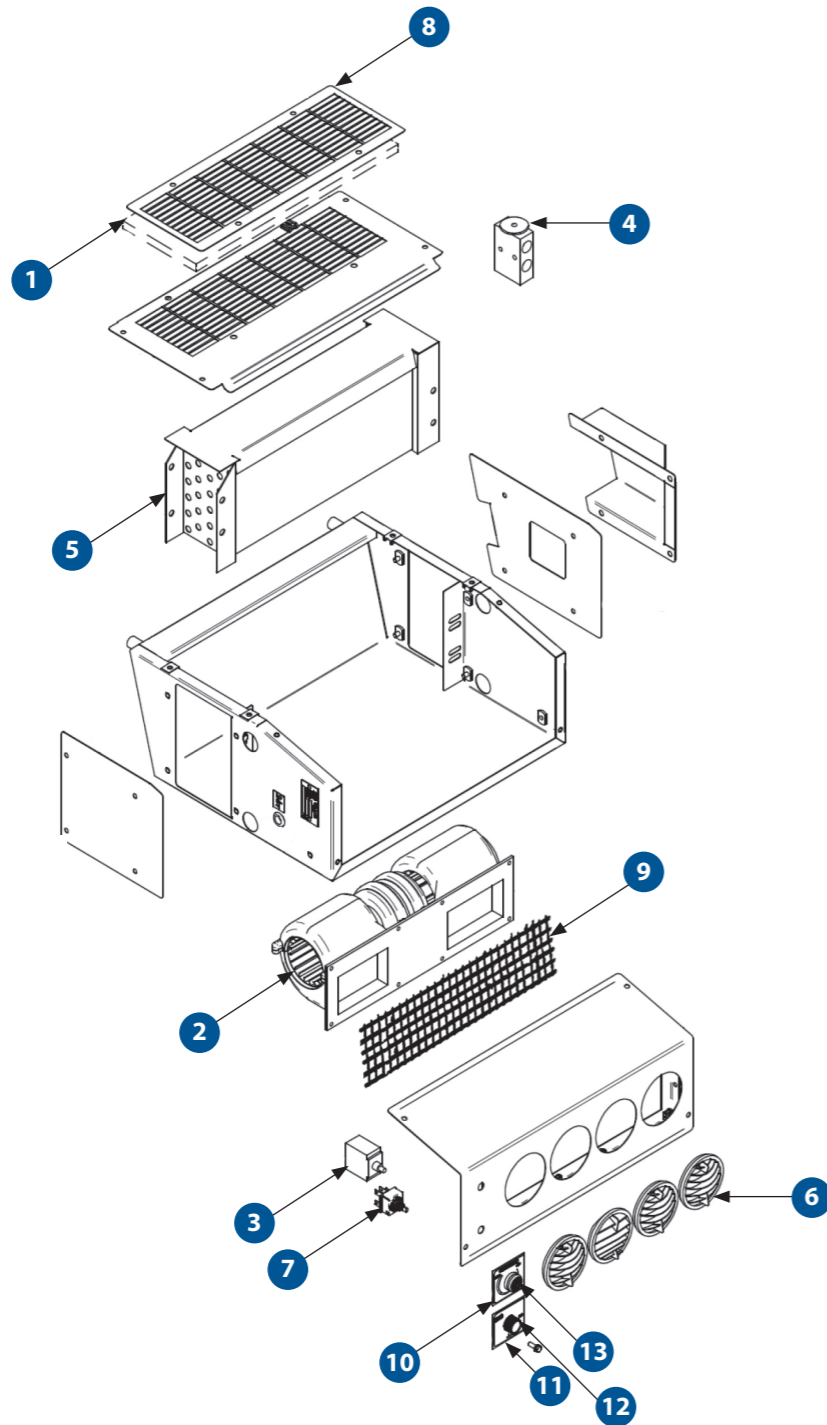

EC121

INTERNAL EVAPORATOR

EC1212 | EC1214



SPARE PARTS

PART NO.	DESCRIPTION	QTY
1	S25011825 EVAPORATOR FILTER MEDIA 385MM X 145MM	1
2	AU400035 FAN DECK 12V 3SPD (EC1212) AU400034 FAN DECK 24V 3SPD (EC1214)	1 1
3	UE016 THERMOSTAT DEICE STUD	1
4	H0092214 TX VALVE	1
5	AU120480 EVAPORATOR COIL 345MM X 152MM X 79MM 4RW	1
6	AU821708 LOUVRE ROUND 3" HOLE	4
7	UE335 ROTARY SWITCH 3-SPEED C/W NUT	1
8	S2501021S FILTER COVER	1
9	S2501207 GRILLE 344MM X 100MM	1
10	AU354351 LABEL STANDARD THERMOSTAT	1
11	AU854350 LABEL AUTOMOTIVE FAN SWITCH	1
12	UC451 KNOB BLACK PLASTIC	1
13	UC022 KNOB SNOWFLAKE	1
	UC504 DRAIN NOZZLE 13MM	4
	AU552403 O RING 134A SIZE 13/32" #8	2
	AU643100 FUSE BLADE MINI 25A AUTO	1
	AU643213 FUSE BLADE MINI 15A AUTO	1

SPECIFICATIONS

	METRIC	IMPERIAL
Cooling Capacity	4.0 kW	13648 BTU
Heating Capacity (Optional)	3.5 kW	11942 BTU
Air Flow	110 l/s	233 CFM
Fresh Air	30 l/s	64 CFM
Power Supply	24V / 12V	24V / 12V
Current Draw	5 A / 10 A	5 A / 10 A
Refrigerant	R134a	R134a
Maximum Ambient Temperature	46°C	115°F
Weight (nominal)	10.0 Kg	22.0 lbs
Technical Manual Reference	SM260-2494	SM260-2494
Dimension L X W X H	550mm X 435mm X 180mm	21.7in X 17.1in X 7.1in

MAINTENANCE

MONTHLY / 300 HOURS

S25011825 EVAPORATOR FILTER MEDIA 385X145MM

ANNUAL / 3,600 HOURS

AU400034 FAN DECK 24V 3SPD

AU400035 FAN DECK 12V 3SPD

3 YEARS / 10,800 HOURS

UE016 THERMOSTAT DEICE STUD

H0092214 TX VALVE BLK

Please contact SIGMA for more information including details on an overhaul scope and interval. Maintenance periods and scope are dependent on application and site conditions, and are to be used as a guide.

COMPANION ITEMS

PART NO.	DESCRIPTION
EC12C4	Electric Condenser
EB9P4X	Pressuriser
HDC150	Hydraulic Compressor
AU2961001	Electric Compressor
AU110388	Radiator Condenser
AU270306	Engine Driven Compressor
AU270307	Engine Driven Compressor
AU2790311	Engine Driven Compressor
AU270312	Engine Driven Compressor
AU531422	Receiver Drier
KIT25014	Heater Kit