

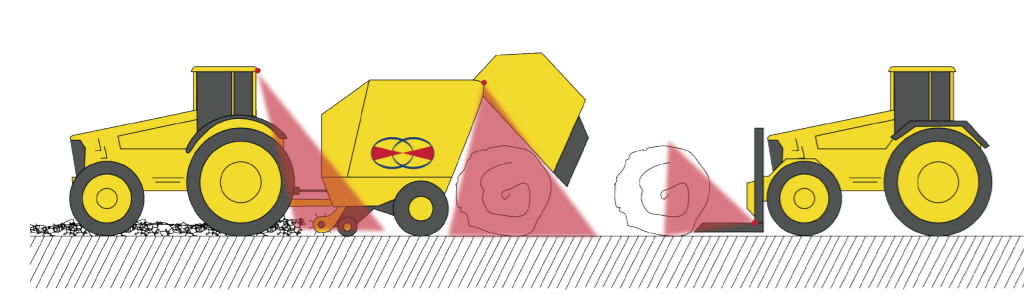

Examples of **Vision solutions**



Rear view / tool view
A rear camera gives an operator good vision when unloading the trailer. It supports safe reversing, and helps prevent damage. It assist in keeping control over the process of the baler, harvester, or other attachments. If the machine needs to be driven on a public road, a rear camera gives the operator a complete view of the traffic behind the machine.

Material handling
Large material can block the view of the operator during maneuvering or while driving. With our special view-on-fork or loader camera the operator can see on the monitor where they should position the forks or loader. This helps to reduce risks for goods and equipment.

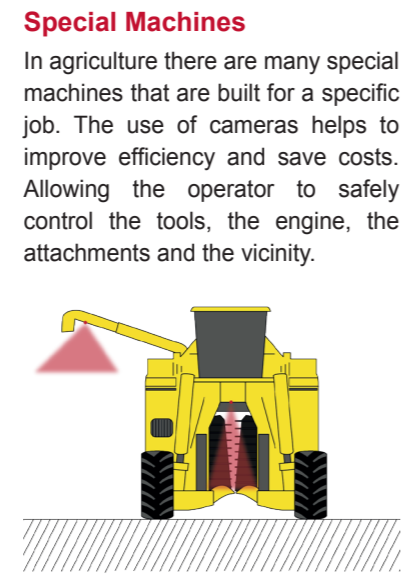

Special Machines
In agriculture there are many special machines that are built for a specific job. The use of cameras helps to improve efficiency and save costs. Allowing the operator to safely control the tools, the engine, the attachments and the vicinity.



At Orlaco, quality is never taken lightly. We keep a clear and persistent focus on customer satisfaction. A focus that is maintained throughout the manufacturing process of our quality products, which are custom designed in various formats. We are able to uphold our level of quality by providing detailed servicing. To top it all off, we have secured the highest achievable automotive certification: IATF 16949.

At Orlaco, we invest in continuous improvement in order to secure a long term, satisfied customer base. We believe that compatibility in products, systems, and operations is the key element to creating reliable partnerships. All our products are controlled and clearly documented to give our customers a zero-defect product that works right, every time.

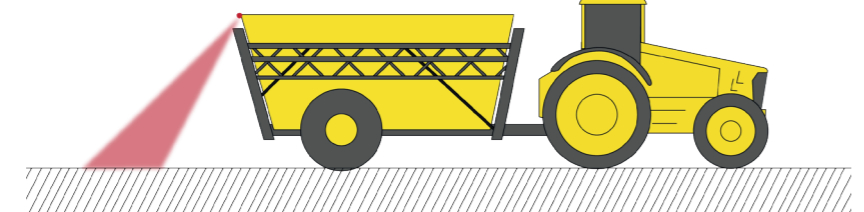

Rear view / tool view
With a tractor-trailer combination, a rear camera improves the operator's view when unloading the trailer, supports safe reversing and helps to prevent damage. If the machine needs to be driven on a public road, a rear camera gives the operator a complete view of the traffic behind the machine.

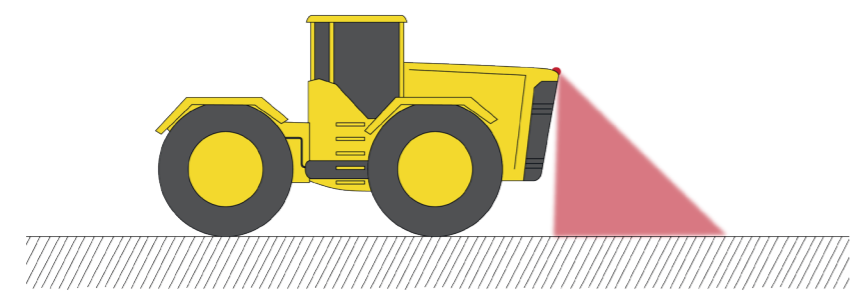

Front view
Increase an operator's total view by using a front cam. Large machines or front attachments can block an operator's view. Increase safety and efficiency by using a front cam. Save money by avoiding damage to the machine and/or the infrastructure.

Surround view

The ultimate view for an operator is a 360° view. But most machine's are too large to allow this kind of overview by the operator. Surround view offers a complete overview. While maneuvering, reversing, or driving Surround view gives the operator a total view around all sides of a machine, without any loss of visibility. This increases the safety, and efficiency of the operator. On ground level the entire surrounding area is visible even within in the corners. Any object, person, or attachment around the entire machine is kept in sight. The images produced by the monitor are not overstretched and shown in relatively normal size, giving the operator a better and quicker understanding of his surroundings.

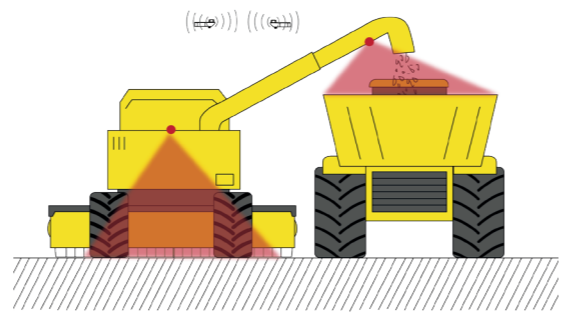
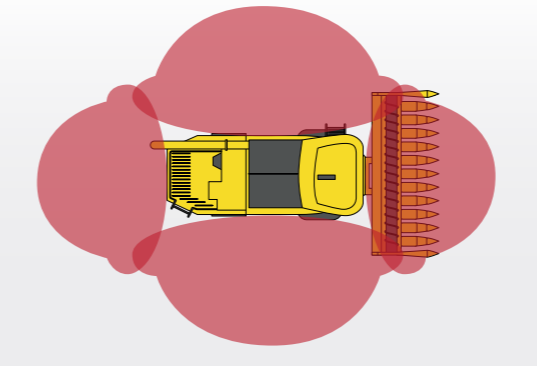

Transmitter-Receiver system
A tractor cab monitor receives images from cameras placed on the auger of a harvester/combine for a clear process viewpoint. It makes the total process more efficient and prevents damage.

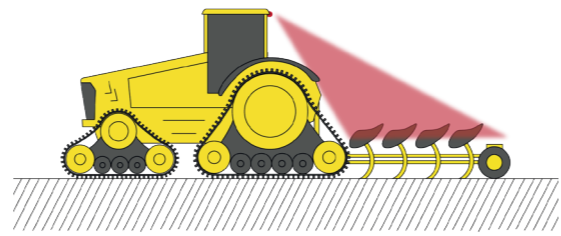

Process view
More comfort, less damage, and better efficiency with a camera placed on your tractor, or other machines. Keep a constant eye on the seeding and planting processes, or during hitching, with an Orlaco camera and monitor that is controlled from the cab.

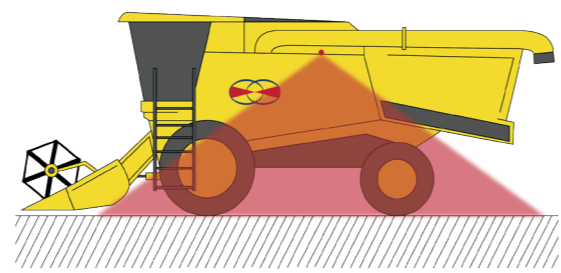

Side view
An operator needs to see what is happening alongside the machine. Drive, maneuver, and turn safer and more easily. A side cam is the solution to turning in tight spaces and seeing what is happening next to the machine.



Toolview example: Image of a toolview on a grader



Toolview
Having a direct view on the process or tools can sometimes be impossible for an machine operator. The use of a camera ensures a clear view on what he is doing.



Combine Harvester

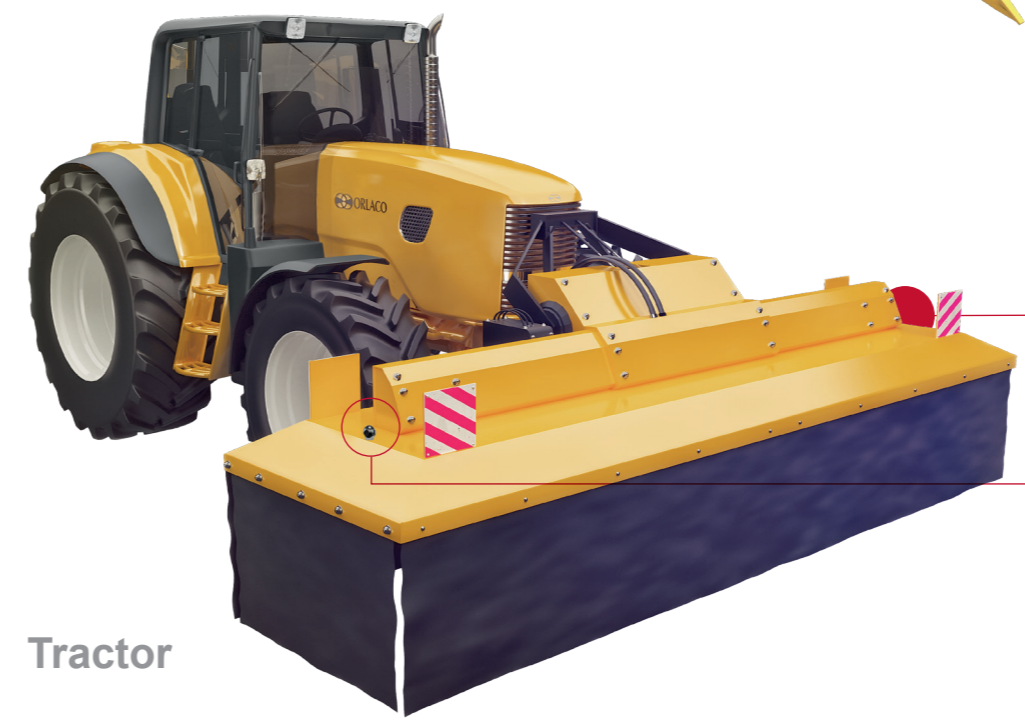

Tractor



Cross view



Turning or crossing the road is not always easy with a machine with front attachments because of the limited visibility from the cab. Cross Traffic View is the solution to do this more safely. The system displays the left and right sides of the approaching road clearly and real-time. This way traffic users can always be identified in time.



Examples of **Active safety solutions**



12" Monitor possibility

RadarEye is an integrated active view system and is designed to detect and see objects in zones obscured from the operator's view. The pulsed-time-domain sensors detect stationary as well as moving objects in a designated coverage area.

With this rearview system the operator is actively warned with audible tones that increase in rate as objects come closer. Detected objects can be seen on the monitor, allowing the operator to respond. This will help the operator prevent vehicle damage and damage to other equipment due to backing accidents. The SRD sensors have a rugged design, are shockproof, and have a waterproof housing.

RadarEye Rear

Use RadarEye Rearview systems for optimal safe reversing. This active view system detects and sees objects at the rear of the vehicle.

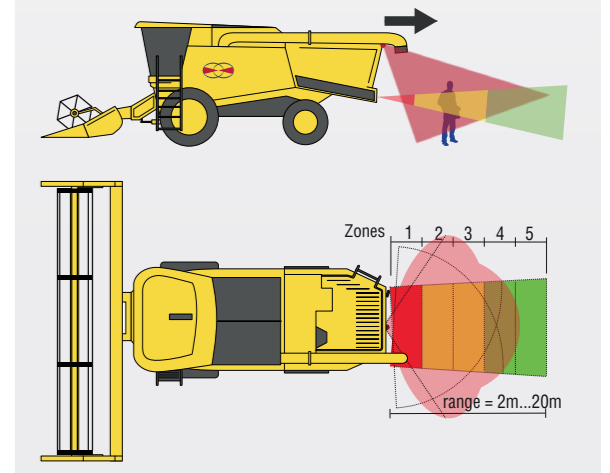

Camera & Monitor possibilities

For more information about Cameras, Monitors, Cables and Accessories please visit www.oralco.com.



Cameras FAMOS

- Lens angles 20° / 40° / 60° / 80° / 102° / 118° / 129° / 170°
- Improved EMC-standards
- Optimized impact- and vibration-resistance
- Watertight IP69K according to DIN 40050-9
- -40° to +85° C operating temperature



Cameras FAMOS IR LED

- Lens angles 80° / 118°
- 4 High Power Infrared LEDs 850nm
- UV-transparent front cover
- Watertight IP69K according to DIN 40050-9
- Shockproof and vibration resistant
- -40° to +85° C operating temperature



Display 7" RLED

- LED Backlight technology
- Brightness automatically adjust to light
- Shockproof and vibration resistant
- Watertight IP67 according to IEC 60529
- -40° to +85° C operating temperature



Monitor 12"

- LED Backlight technology
- Brightness automatically adjust to light
- Shockproof and vibration resistant
- -40° to +85° C operating temperature



Orlaco cables

Armored cable specially for severe off-road conditions
 • This is due to the additional internal galvanised braided steel wire armor

Multi cable standard

- This standard cable can be used on all AG/HE machines if no special requirements is needed



Spectrum Scanner wireless video transmitter & receiver

- Available as omnidirectional antenna with horizontal orientation or directional antenna with vertical orientation
- Maximum range 150m or 300m (dependent on surroundings)
- 8 video channels
- Full On Screen Display (OSD) functionality for system settings



MultiView box

- Full screen, split screen, picture in picture or quad split
- 4 channels
- Stainless steel housing
- Serial Orlaco Monitor needed



SRD Sensors

- Integrated in Camera-Monitor system
- Active detection system
- 2m...20m detection area, divided in 5 equally sizes segments
- Obstacle reaction delay 50ms



RadarEye Interface box for existing monitors

- To connect the RadarEye active detection system to non-radar (third party) monitors
- Set consists of interface box, external speaker, adapter plug and open wired multicable with 8p connector

It is Orlaco's viewpoint that optimal vision around every vehicle and vessel should be the norm. It provides safety, less damage, comfort and efficiency. *Vision is our mission®*. A revealing mission. We develop professional vision solutions for every situation:



HEAVY EQUIPMENT



ON ROAD TRUCKS



CRANES



FORKLIFTS



MARITIME



EMERGENCY VEHICLES



MILITARY VEHICLES



Orlaco Products B.V. Headquarters Worldwide

- Albert Plesmanstraat 42
PO box 193
3770 AD Barneveld
The Netherlands
- Phone +31 (0) 342 404 555
- info@oralco.com
- www.oralco.com

[Check our website for all our brochures \(pdf\).](#)



Vision is our mission®



AGRICULTURE MACHINES VISION SOLUTIONS

